

**PVC Finished Calcium Sulphate Core Raised Flooring**

**Sketch:**

- 1 Floor panel coated with anti-static PVC finish
- 2 Gasket
- 3 Pedestal (construction type depends on floor height)
- 4 Base plate glued to the subfloor, can be doweled by EXPANSION BOLT on request

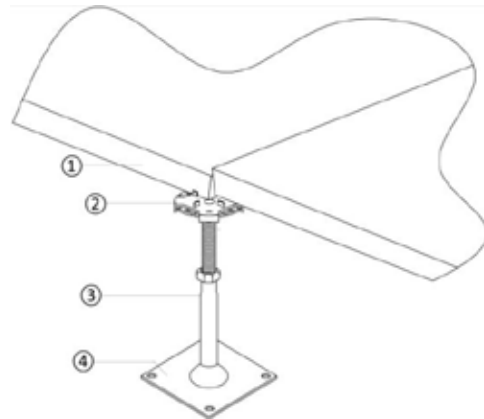

**Panel:**

|                       |   |
|-----------------------|---|
| Dimensions:           | 600 x 600 mm (special dimintions possible)                        |
| Panel thickness:      | 32,0 mm   |
| Surface of the panel: | coated with anti-static PVC                                       |
| Underside :           | coated with 0.5mm galvanized steel sheet                          |
| System weight:        | Approx. 60 kg/m <sup>2</sup> (with covering, floor height 250 mm) |
| Panel material:       | 30mm Calcium Sulphate   |
| Fire Resistance       | F 30, DIN 4102  |

**Substructure:**

|                      |                  |
|----------------------|------------------|
| Pedestal module:     | 600 mm           |
| Pedestal material:   | Galvanized steel |
| Construction height: | 250 mm variable  |
| Stringer:            | 540*20*30*1.0mm  |

**Load values\*:**

|  |                                  |
|--|----------------------------------|
| Concentrated load:                       | 4690 N                           |
| Tested acc. to DIN EN 12825              | Class 6                          |
| Impact load:                             | ≥536N                            |
| Ultimate load                            | ≥10680N                          |
| Rolling load:                            | 10times 4690N & 10000times 2670N |
| Distributed load :                       | 36100 N/m <sup>2</sup>           |
| Point Load Heavy middle of the panel:    | ≈ 600 kg                         |
| Point Load Breaking middle of the panel: | ≈ 2000 kg                        |
| Resistance to Earth                      | ≥10 <sup>6</sup> Ω (ohms)        |

**KARACHI - HEAD OFFICE**  
 1-6, A/1 P.E.C.H.S, MAIN  
 SHAHRA-E-FAISAL,  
 KARACHI - 75400  
 PHONE: 021 3453 5377-9  
 CELL: 0300 8542220

**KARACHI - DEFENCE SHOWROOM**  
 2C, MAIN 26TH STREET CORNER OF  
 KHY-E-TANZEEM, DHA, PHASE-V,  
 KARACHI  
 PHONE: 021 3537 4864  
 CELL: 0307 7774780

**KHI - BAHRIA SHOWROOM**  
 SHOP#14, SHOPPING GALLERY  
 PRECINCT 2, NEXT TO BILAL  
 DEPARTMENT STORE,  
 BAHRIA TOWN, KARACHI  
 CELL: 0307 3335525

**LAHORE SHOWROOM**  
 MALL 94, 2ND FLOOR,  
 94-D-1,(NEXT TO MALL 1),  
 MAIN BOULEVARD  
 GULBERG - III, LAHORE  
 CELL: 0307 7774513

**ISLAMABAD - HEAD OFFICE**  
 1-A, MAIN KOHISTAN ROAD,  
 STREET 9, SECTOR F-8/3  
 ISLAMABAD  
 PHONE: 051 285 3966  
 CELL: 0303 7774248

[www.theprotectors.com.pk](http://www.theprotectors.com.pk)  
[sales@theprotectors.com.pk](mailto:sales@theprotectors.com.pk)

 /theprotectors

**UAN 021-111-BLINDS (111 254 637)**  
 0300 0341 003